

SineWave Part Number	Schematic Drawing#	Approx Weight (LBS)
KMG45C01A	24281-11A	173
KMG45C01P	24281-11P	174

HorsePower (HP)	kVar	Max Amps	Voltage (V)	HZ	Phase
40	4.3	45	600	60	3

1

Thermal Switch Terminal Block

Wire Range: 18 AWG To 4 AWG.
Torque: 20 LB-IN (2.3 Nm)
Switch Opens on Temperature Rise
Contact Rating: 6A @ 120 VAC

D

C

A

B

A

A

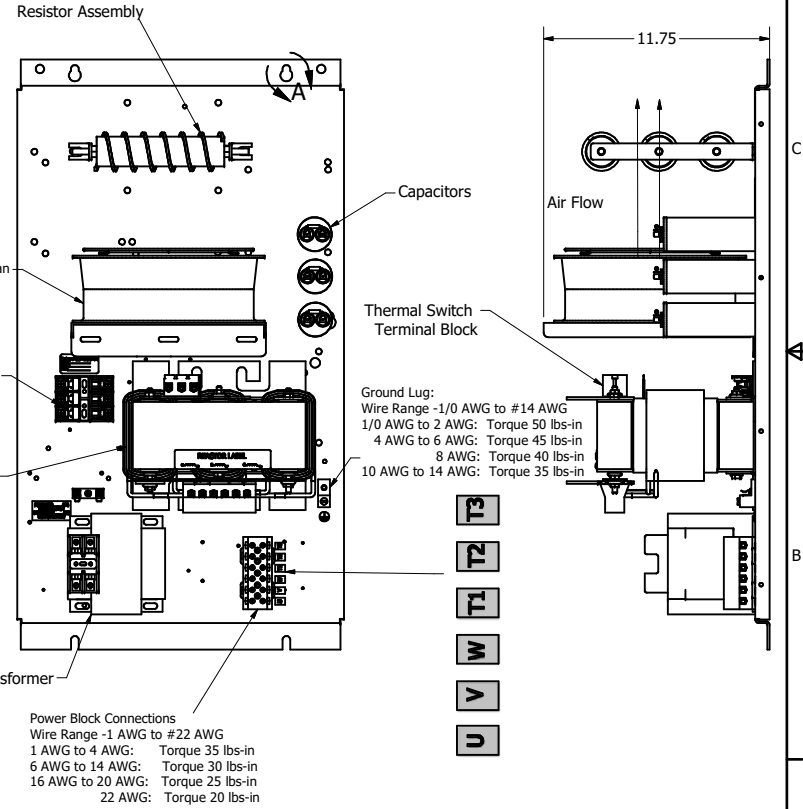
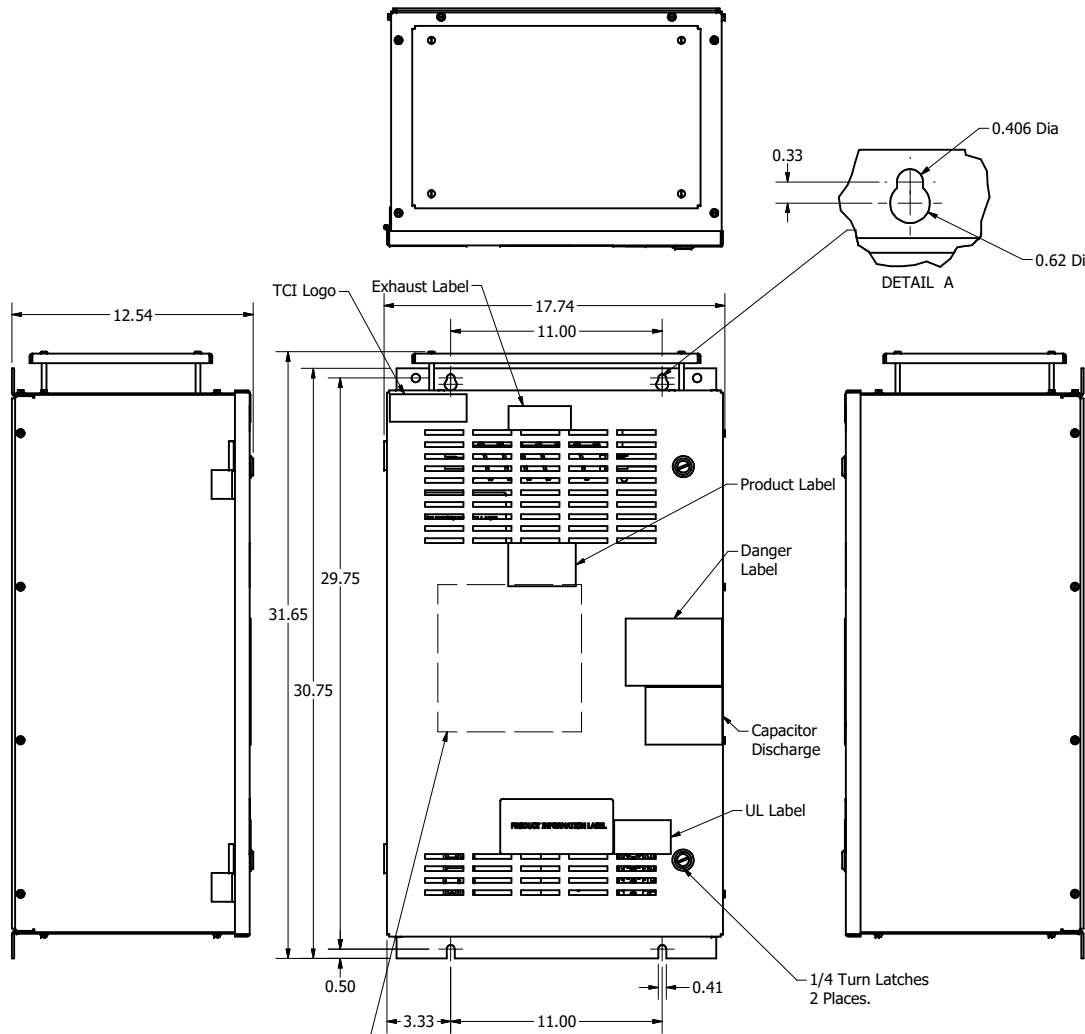

PQconnect Board Mounted On Inside Front Door. OPTIONAL

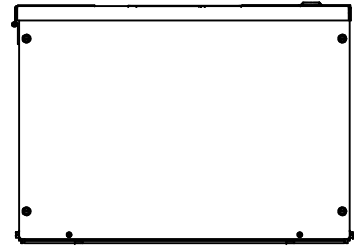
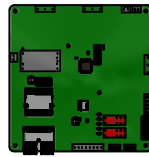

Customer Is Responsible For Installation to Meet All National And Local Electrical Codes.

Material(s) Shall be RoHS Compliant

TCI, LLC CLAIMS PROPRIETARY RIGHTS IN THE MATERIAL HEREIN DISCLOSED. IT IS SUPPLIED WITHOUT PREJUDICE TO ANY PATENT RIGHTS OF TCI AND MAY NOT BE REPRODUCED OR USED TO MANUFACTURE ANYTHING SHOWN THEREIN WITHOUT WRITTEN PERMISSION FROM TCI.					TOLERANCES (EXCEPT AS NOTED)	W132 N10611 Grant Drive Germantown, WI 53022 KMG45C01-, SineWave Filter Enclosed Type 1, 40HP, 600V 104441DG DATE: 10/14/2016 SCALE: 1/8 SHEET 1 OF 1
					DECIMAL	
					.XX ± .25 .XXX ± .10	
					FRACTIONAL	
B Add PQconnect Board	9/22/2020	DSW			± 1/16	
NO REVISION					ANGULAR ± 1°	